

Tiller

650 RTT

96093000202

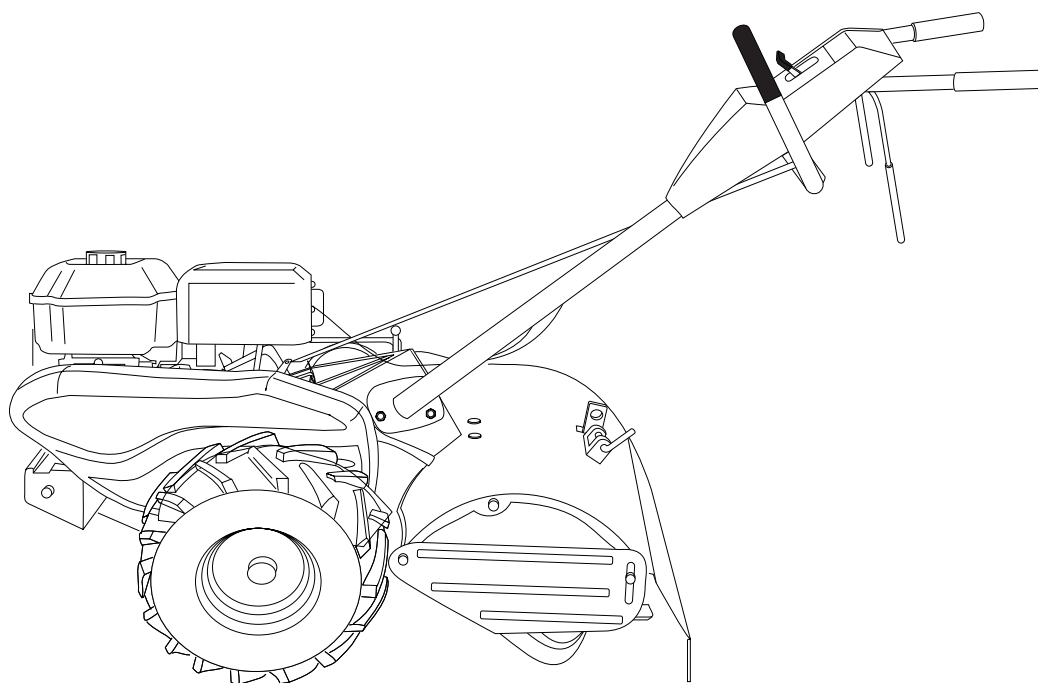

Illustrated Parts List

REPAIR PARTS

TILLER - - MODEL NUMBER 650RTT (96093000202), PRODUCT NUMBER 960 93 00-02
HANDLE ASSEMBLY

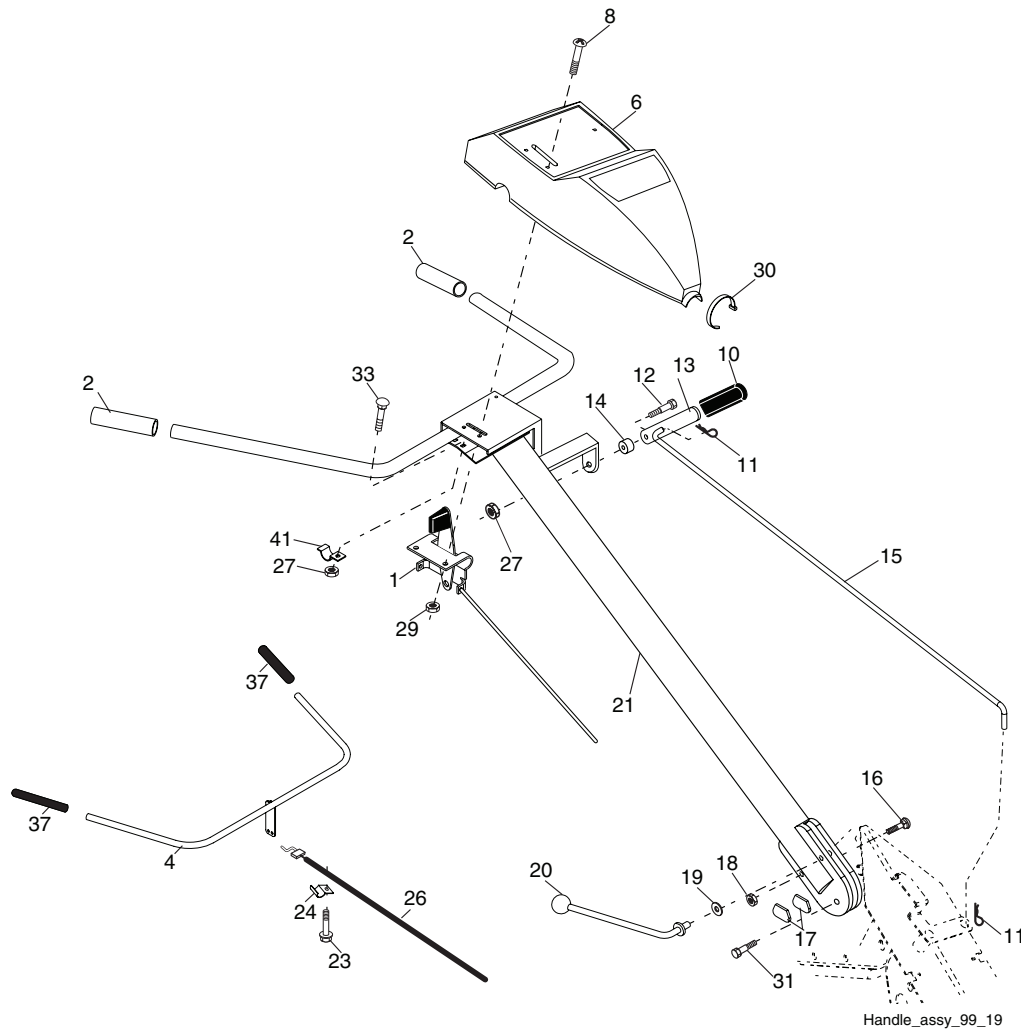

Handle_assy_99_19

KEY NO.	PART NO.	DESCRIPTION
1	532 18 94-82	Control, Throttle
2	532 16 57-87	Grip, Handle
4	532 15 92-28	Bar Assembly, Control
6	532 18 06-76	Panel, Control
8	871 19 10-08	Screw, Truss Hd. #10-24 unc x 1/2
10	532 12 47-97	Grip, Handle
11	532 12 47-88	Clip, Hairpin
12	532 08 13-28	Bolt, Shoulder
13	532 18 74-97	Handle, Shift
14	532 10 93-13	Grommet, Rubber
15	532 10 93-37	Rod, Shift
16	872 11 06-08	Bolt, Carriage 3/8-16 x 1 Gr. 5
17	532 10 92-29	Lock, Handle
18	873 68 06-00	Nut, Crownlock 3/8-16 unc
19	819 13 16-11	Washer 13/32 x 1 x 11 Ga.
20	532 10 92-28	Lever, Lock, Handle

KEY NO.	PART NO.	DESCRIPTION
21	532 18 11-27	Handle
23	532 08 67-77	Screw, Hex Washer SLT#10-24 x .50
24	532 00 94-84	Clip
26	532 15 92-31	Cable, Clutch
27	873 90 04-00	Nut, Hex Flange 1/4-20 unc
29	873 73 10-00	Nut, Keps #10-24 unc
30	532 10 41-64	Tie, Cable
31	532 15 06-96	Bolt, Pivot
33	872 14 04-04	Bolt, Carriage 1/4-20 unc x 1/2
37	532 10 26-04	Grip, Bar, Control
41	532 10 27-44	Clamp, Bar, Control

NOTE: All component dimensions given in U.S. inches.
1 inch = 25.4 mm

REPAIR PARTS

TILLER - - MODEL NUMBER 650RTT (96093000202), PRODUCT NUMBER 960 93 00-02
 MAINFRAME, LEFT SIDE

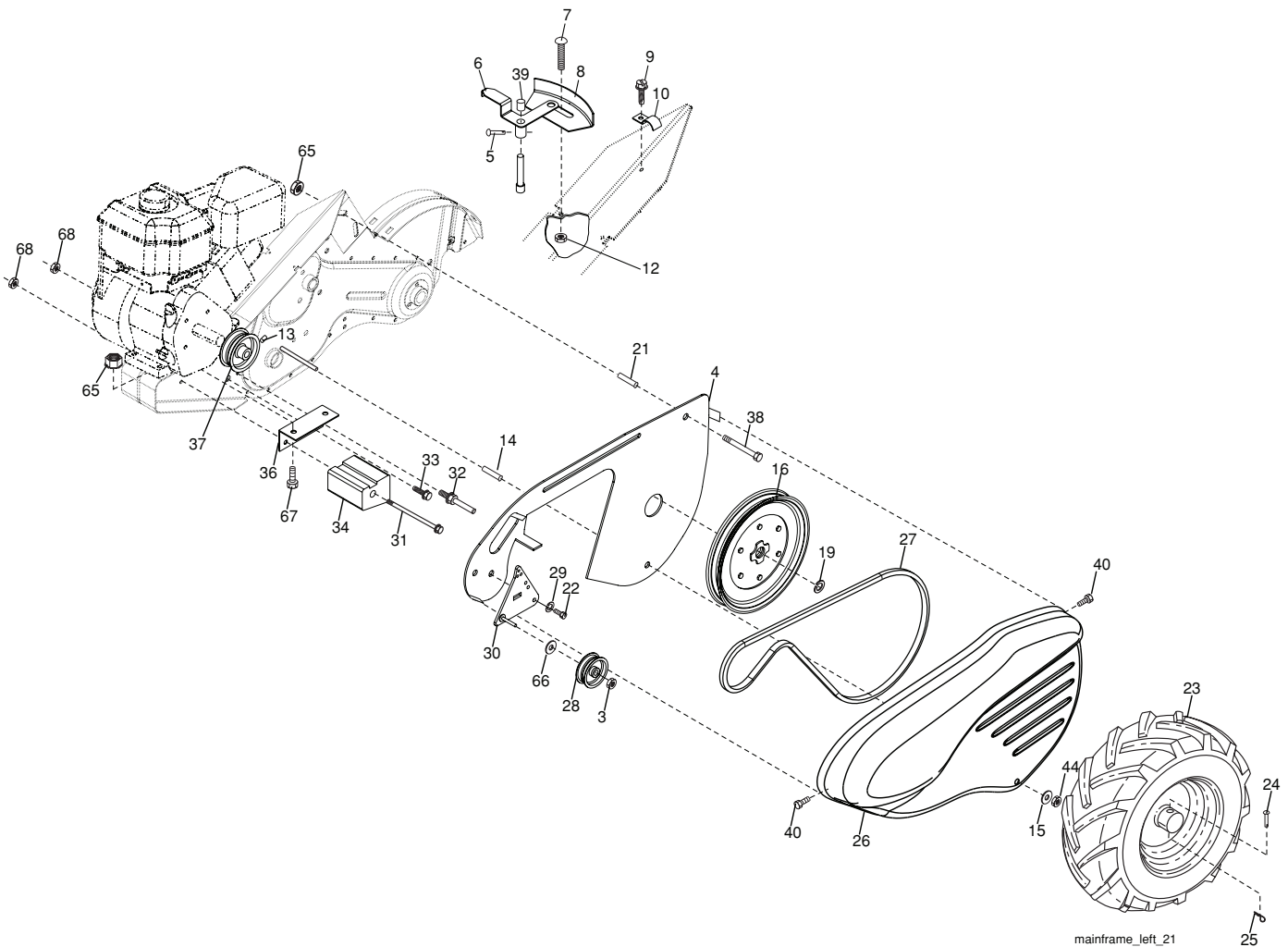

KEY NO.	PART NO.	DESCRIPTION
3	873 22 06-00	Nut, Hex 3/8-16
4	532 17 01-27	Shield, Inner Belt Guard RT
5	532 16 43-29	Pin Spirol Flared
6	532 11 01-11	Lever, Shift
7	872 11 04-04	Bolt, Carriage 1/4-20 x 1/2 Gr. 5
8	532 00 87-00	Plate, Shift Indicator
9	532 08 67-77	Screw, Hex, Washer Head, Slotted #10-24 x 1/2
10	532 00 94-84	Clip
12	873 51 04-00	Nut, Keps Hex 1/4-20 unc
13	823 23 05-06	Screw, Set, Hex 5/16-18 x 3/8
14	532 11 06-52	Spacer, Split 0.327 x 0.42 x 2.09
15	819 11 11-16	Washer 11/32 x 11/16 x 16 Ga.
16	532 14 51-02	Sheave, Transmission
19	812 00 00-28	Retainer, Ring
21	532 15 61-17	Spacer, Split
22	874 77 05-08	Bolt, Fin Hex 5/16-24 unf x 1/2
23	532 00 50-15	Tire
	532 12 43-66	Rim
	532 12 47-18	Tire Valve
24	532 12 68-75	Rivet, Drilled
25	532 12 47-88	Clip, Hairpin

KEY NO.	PART NO.	DESCRIPTION
26	532 16 67-92	Guard, Belt
27	532 13 28-01	Belt, V
28	532 10 46-79	Pulley, Idler
29	812 00 00-32	Ring, Klip
30	532 15 92-29	Bracket, Idler
31	532 10 23-84	Bolt, Hex 5/16-16 x 12
32	532 10 21-41	Shaft, Idler Arm
33	874 76 06-16	Bolt, Hex 3/8-16 x 1
34	532 10 23-83	Counterweight, L. H.
36	532 10 23-31	Bracket, Reinforcement, L. H.
37	532 13 08-12	Sheave, Engine
38	874 76 05-44	Bolt, Fin Hex 5/16-18 unc x 2-3/4
39	532 14 00-62	Cap, Plunger Blk
40	532 17 04-88	Screw Hex Wsh Slit #10-24 x 1/2
44	873 80 05-00	Nut Lock Hex w/Ins 5/16-18 unc PL
65	873 97 05-00	Nut Lock Hex Flange
66	819 13 13-12	Washer 13/32 x 13/16 x 12 Ga.
67	874 76 05-24	Bolt, Hex 5/16-18 x 1-1/2
68	873 51 06-00	Nut, Keps Hex 3/8-16 unc

NOTE: All component dimensions given in U.S. inches.
 1 inch = 25.4 mm

REPAIR PARTS

TILLER - - MODEL NUMBER 650RTT (96093000202), PRODUCT NUMBER 960 93 00-02
 MAINFRAME, RIGHT SIDE

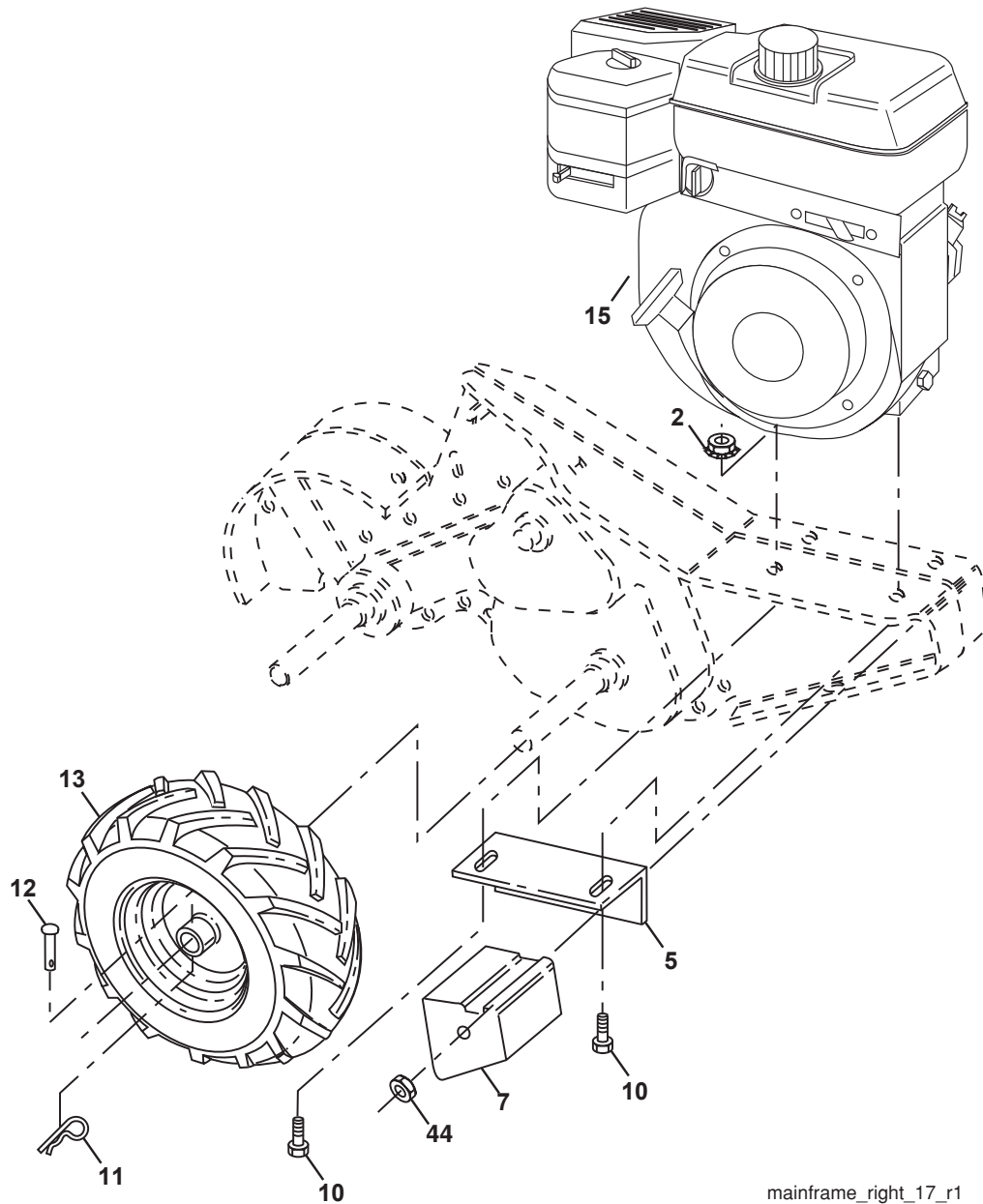

KEY NO.	PART NO.	DESCRIPTION
2	873 97 05-00	Locknut, Hex, Flange 5/16-18
5	532 10 23-32	Bracket, Reinforcement RH
7	532 10 21-73	Counter Weight, R.H.
10	874 76 05-24	Bolt, Hex 5/16-18 x 1-1/2
11	532 12 47-88	Clip, Hairpin
12	532 12 68-75	Rivet, Drilled
13	532 00 50-15	Tire
	532 12 43-66	Rim
	532 12 47-18	Tire Valve

KEY NO.	PART NO.	DESCRIPTION
15	-----	Engine, Briggs & Stratton Model No. 120202 (Order parts from Engine Manufacturer)
44	873 51 06-00	Nut, Keps Hex 3/8-16 unc

NOTE: All component dimensions given in U.S. inches
 1 inch = 25.4 mm
 For engine service and replacement parts, call the toll free number for your engine manufacturer listed below:
 Briggs & Stratton 1-800-233-3723

REPAIR PARTS

TILLER - - MODEL NUMBER 650RTT (96093000202), PRODUCT NUMBER 960 93 00-02
TRANSMISSION

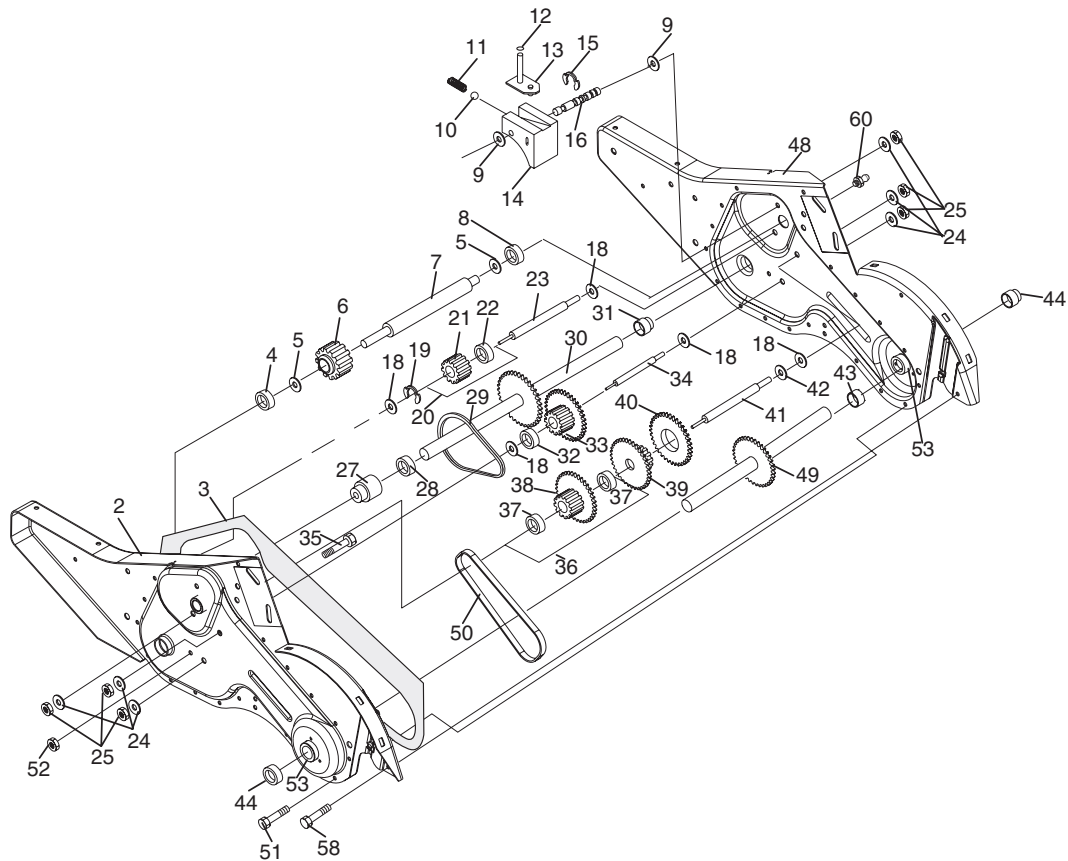

transmission_19.5b

KEY NO.	PART NO.	DESCRIPTION	KEY NO.	PART NO.	DESCRIPTION
1	532 18 85-54	Transmission Assembly (Includes Key Nos. 2-53)	29	532 10 21-34	Chain #35-50 Pitch
2	532 18 84-82	Gearcase, L.H. w/Bearing (Includes Key No. 4)	30	532 15 07-37	Ground Shaft Assembly
3	532 16 19-63	Gasket, Gearcase	31	532 14 30-08	Bearing, Shaft, Ground Drive R.H.
4	532 00 50-20	Bearing, Needle	32	532 10 63-88	Spacer 0.70 x 1.00 x 1.150
5	532 00 13-70	Washer, Thrust 5/8 x 1.10 x 1/32	33	532 10 21-21	Sprocket and Gear Assembly
6	532 13 73-35	Pinion, Input	34	532 10 21-12	Shaft, Reduction (2nd)
7	532 14 51-01	Shaft, Input	35	532 10 21-01	Screw, Whiz, Lock 5/16-18 x 3-1/2
8	532 12 47-92	Bearing, Needle	36	532 15 43-55	Sprocket Assembly w/Bearing (Includes Key Nos. 37 and 38)
9	532 15 44-67	Washer, Seal	37	532 12 47-91	Bearing, Needle
10	532 12 46-97	Ball, Steel	38	532 15 43-56	Sprocket, Tine
11	532 10 03-71	Spring, Shift, Fork	39	532 10 53-45	Gear, Cluster, Red 1st & 2nd
12	532 10 61-60	O-Ring	40	532 10 53-46	Gear, Reverse
13	532 14 21-45	Arm, Shift	41	532 00 83-58	Shaft, Reduction (1st)
14	532 00 83-53	Fork, Shift	42	532 00 42-20	Washer, Thrust
15	812 00 00-39	Ring, Klip	43	532 10 61-46	Spacer 1.01 x 1.75 x 0.760
16	532 15 44-66	Shaft, Shift	44	532 15 52-36	Seal Asm, Oil
18	532 00 43-58	Washer	48	532 18 84-85	Gearcase, R.H. w/Bearing (Includes Key No. 8)
19	812 00 00-40	Ring, Klip	49	532 13 26-88	Shaft, Tine
20	532 10 21-14	Gear, Assembly, Reverse Idler (Includes Key Nos. 21 and 22)	50	532 10 61-47	Chain, Roller #50-50 Pitch
21	532 10 21-15	Gear, Reverse Idler	51	817 72 04-08	Screw 1/4-20 x 1/2
22	532 00 68-03	Bearing, Needle	52	873 22 05-00	Nut, Hex 5/16-18
23	532 10 21-11	Shaft, Reverse Idler	53	532 16 51-40	Kit, Bearing
24	810 04 07-00	Washer, Lock 7/16	58	532 17 95-20	Bolt Shoulder 1/4-20 unc x .875
25	873 61 07-00	Nut, Hex 7/16-20	60	532 18 32-26	Fitting Grease
27	532 14 30-09	Bearing, Shaft, Ground Drive L.H.	--	532 00 60-66	Grease, Plastilube #1
28	532 10 63-90	Spacer 0.765 x 1.125 x 1.23			

NOTE: All component dimensions given in U.S. inches.
1 inch = 25.4 mm

REPAIR PARTS

TILLER - - MODEL NUMBER 650RTT (96093000202), PRODUCT NUMBER 960 93 00-02
TINE SHIELD

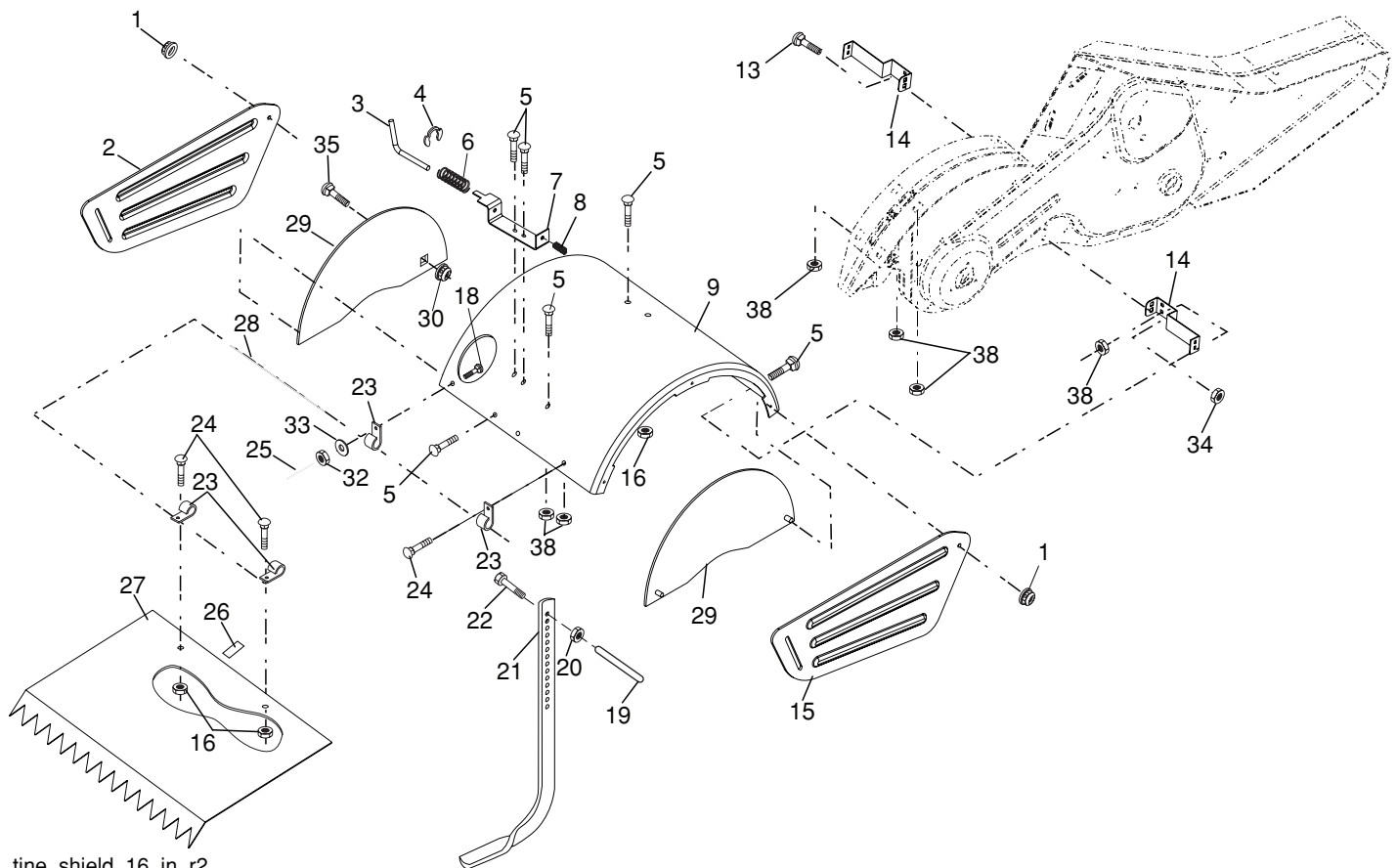

tine_shield_16_in_r2

KEY NO.	PART NO.	DESCRIPTION
1	873 90 05-00	Nut, Lock Hex Flange 5/16-18
2	532 16 29-52	Shield, Side, Outer L. H.
3	532 00 83-93	Pin, Stake, Depth
4	812 00 00-35	Ring, Klip
5	532 18 08-47	Bolt, Rdhd Sqnk 5/16-18 x 3/4
6	532 00 83-94	Spring
7	532 00 83-92	Bracket, Latch
8	532 10 92-30	Spring, Depth Stake
9	532 14 22-92	Shield, Tine
13	872 11 05-10	Bolt, Carriage 5/16-18 x 1-1/4
14	532 12 43-11	Bracket, Shield Tine
15	532 16 29-53	Shield, Side, Outer R.H.
16	873 90 04-00	Nut, Hex Flange 1/4-20 unc
18	872 04 04-10	Bolt, Carriage 1/4-20 x 1-1/4 Gr.
19	532 10 27--01	Grip
20	873 22 06-00	Nut, Hex 3/8-16
21	532 10 21-56	Stake, Depth

KEY NO.	PART NO.	DESCRIPTION
22	874 93 06-32	Bolt, Hex 3/8-16 x 2
23	532 00 44-40	Hinge
24	872 14 04-04	Bolt, Carriage 1/4-20 x 1/2 Gr. 5
25	532 12 47-17	Cap, Vinyl
26	532 10 92-27	Pad, Idler
27	532 12 50-16	Shield, Leveling
28	532 12 05-88	Pin, Hinge
29	532 14 22-93	Shield, Side
30	873 97 05-00	Nut Lock Hex Flange
32	873 22 04-00	Nut Fin Hex 1/4-20 unc
33	810 04 04-00	Washer Lock Hvy Helical 1/4
34	873 51 05-00	Locknut, Hex 5/16-18
38	873 51 05-00	Nut, Keps Hex 5/16-18 unc

NOTE: All component dimensions given in U.S. inches.
1 inch = 25.4 mm

REPAIR PARTS

TILLER - - MODEL NUMBER 650RTT (96093000202), PRODUCT NUMBER 960 93 00-02
TINE ASSEMBLY

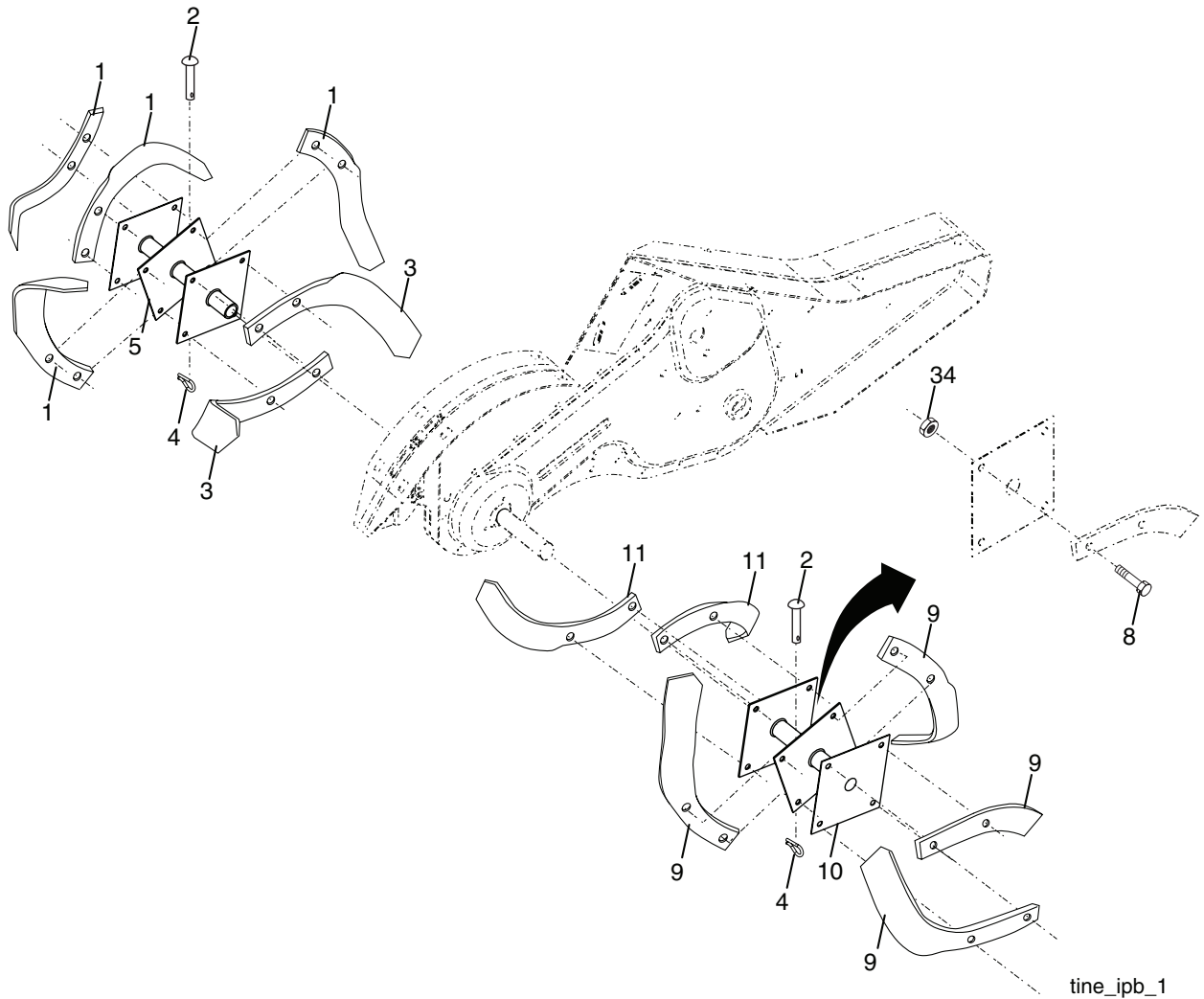

KEY NO.	PART NO.	DESCRIPTION
1	532 00 44-59	Tine, Outer, L.H.
2	532 13 26-73	Clevis Pin
3	532 00 65-54	Tine, Inner, L.H.
4	532 12 46-60	Retainer, Spring Zinc
5	532 13 27-27	Assembly, Hub and Plate, L.H.
8	874 61 06-16	Bolt, Hex 3/8-24 x 1
9	532 00 44-60	Tine, Outer, R.H.

KEY NO.	PART NO.	DESCRIPTION
10	532 13 27-28	Assembly, Hub and Plate, R.H.
11	532 00 65-55	Tine, Inner, R.H.
34	873 54 06-00	Nut Crownlock 3/8-24

NOTE: All component dimensions given in U.S. inches.
1 inch = 25.4 mm

REPAIR PARTS

TILLER - - MODEL NUMBER 650RTT (96093000202), PRODUCT NUMBER 960 93 00-02
DECALS

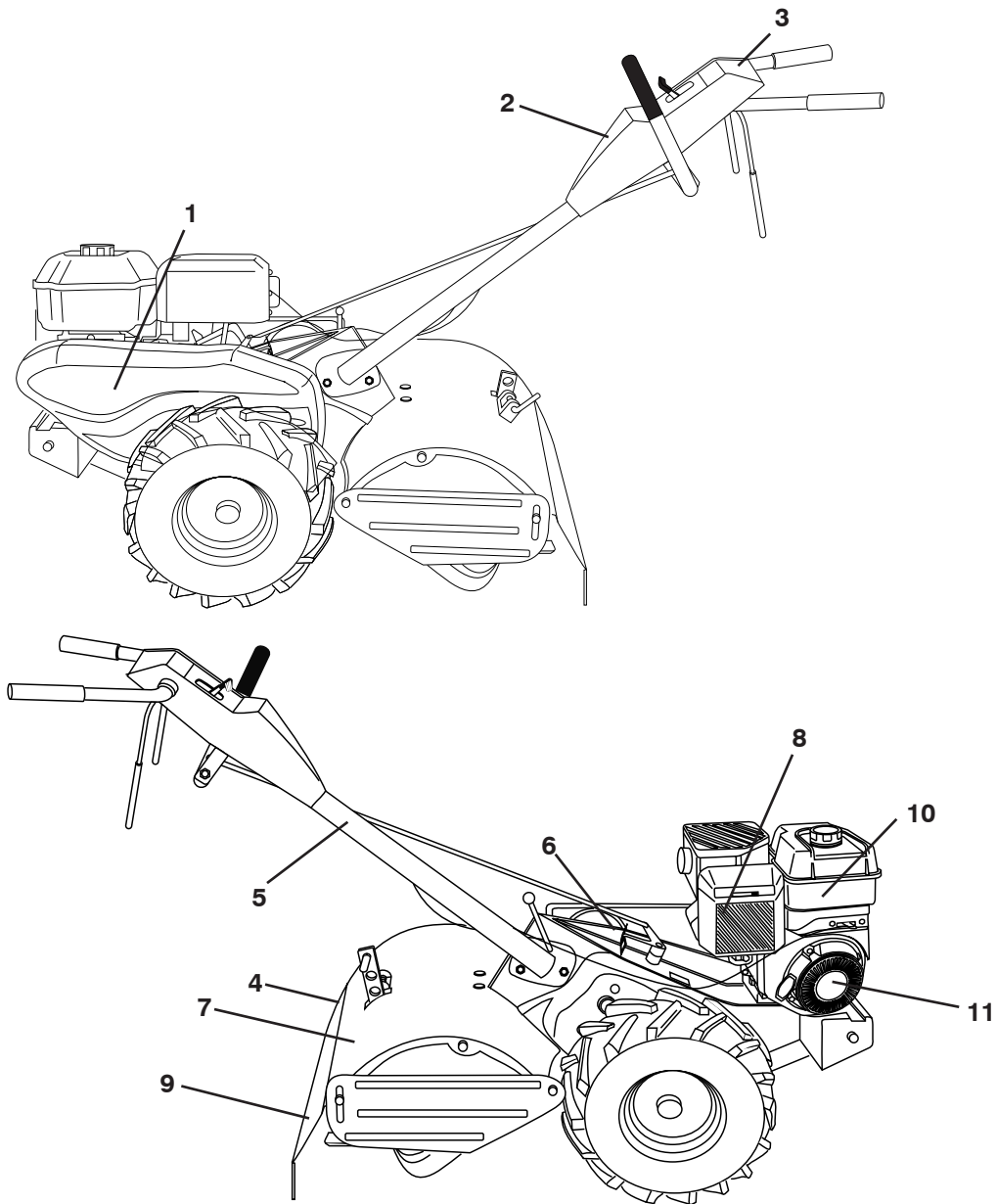

KEY NO.	PART NO.	DESCRIPTION
1	532 41 83-94	Decal, Belt Guard
2	532 41 83-98	Decal, Husqvarna, Control Panel
3	532 18 08-13	Decal, Control Tine
4	532 41 84-73	Decal, Tine Shield
5	532 11 06-14	Decal, Hand Placement
6	532 10 21-80	Decal, Shift Indicator
7	532 16 23-84	Decal, Warning
8	532 40 91-40	Decal, Engine, 8.5
9	532 12 00-76	Decal, Warning, Rotating Tines
10	532 40 91-39	Decal, Engine, Fuel Tank, 8.5
11	532 41 18-16	Decal, Rewind Starter, B&S
--	532 41 81-65	Owner's Manual (English)
--	532 41 81-66	Owner's Manual (French)

